

# Smart Energy Controller



## Active Safety

AI Powered  
Active Arcing Protection



## Higher Yields

Up to 30% More Energy  
with Full Optimizer



## Flexible Communication

WLAN, Fast Ethernet, 4G  
Communication Supported

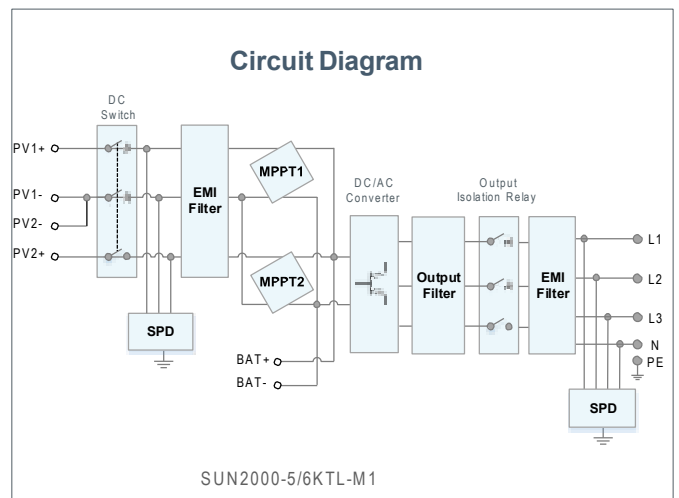
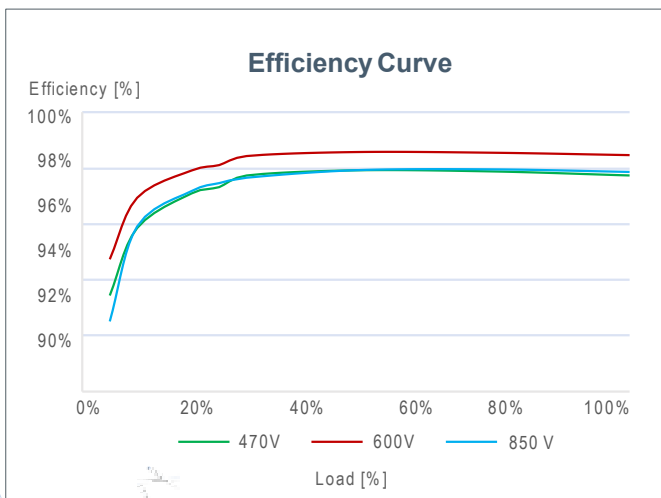

SUN2000-5/6/8/10KTL-M1(High Current Version)  
**Technical Specification**

Technical Specification	SUN2000-5KTL-M1	SUN2000-6KTL-M1	SUN2000-8KTL-M1	SUN2000-10KTL-M1
<b>Efficiency</b>				
Max. efficiency	98.4%	98.6%	98.6%	98.6%
European weighted efficiency	97.5%	97.7%	98.0%	98.1%
<b>Input (PV)</b>				
Recommended max. PV power <sup>1</sup>	7,500 Wp	9,000 Wp	12,000 Wp	15,000 Wp
Max. input voltage <sup>2</sup>	1,100 V			
Operating voltage range <sup>3</sup>	140 V ~ 980 V			
Start-up voltage	200 V			
Rated input voltage	600 V			
Max. input current per MPPT	13.5 A			
Max. short-circuit current	19.5 A			
Number of MPP trackers	2			
Max. number of inputs	2			
<b>Input (DC Battery)</b>				
Compatible Battery	HUAWEI Smart String ESS 5kWh – 30kWh			
Max number of connected battery	2			
Operating voltage range	600 V ~ 980 V			
Max operating current	16.7 A			
Max charge Power	10,000 W			
Max discharge Power	5,000 W	6,000 W	8,000 W	10,000 W
<b>Output</b>				
Grid connection	Three-phase			
Rated output power	5,000 W	6,000 W	8,000 W	10,000 W
Rated AC apparent power	5,000 VA	6,000 VA	8,000 VA	10,000 VA
Max. apparent power	5,500 VA	6,600 VA	8,800 VA	11,000 VA
Rated output voltage	230 Vac / 400 Vac, 3W / N+PE			
Rated AC grid frequency	50 Hz / 60 Hz			
Max. output current	8.5 A	10.1 A	13.5 A	16.9 A
Adjustable powerfactor	0.8 leading ... 0.8 lagging			
Max. total harmonic distortion	≤ 3 %			
Backup power output	Yes (via BackupBox-B1)			
<b>Features &amp; Protections</b>				
Input-side disconnection device	Yes			
Anti-Islanding protection	Yes			
DC reverse polarity protection	Yes			
Insulation monitoring	Yes			
DC surge protection	Yes, compatible with TYPE II protection class according to EN/IEC 61643-11			
AC surge protection	Yes, compatible with TYPE II protection class according to EN/IEC 61643-11			
Residual current monitoring	Yes			
AC overcurrent protection	Yes			
AC short-circuit protection	Yes			
AC overvoltage protection	Yes			
Arc fault protection	Yes			
Ripple receiver control	Yes			
Integrated PID recovery <sup>4</sup>	Yes			
Battery reverse charging from grid	Yes			
<b>General Data</b>				
Operating temperature range	-25 ~ + 60 °C (-13 °F ~ 140 °F)			
Relative operating humidity	0 % RH ~ 100 % RH			
Operating altitude	0 ~ 4,000 m (13,123 ft.) (Derating above 2000 m)			
Cooling	Natural convection			
Display	LED Indicators; Integrated WLAN + FusionSolar App			
Communication	RS485; WLAN/Ethernet via Smart Dongle-WLAN-FE; 4G / 3G / 2G via Smart Dongle-4G (Optional)			
Weight (incl. mounting bracket)	17 kg (37.5 lb)			
Dimension (incl. mounting bracket)	525 x 470 x 146.5 mm (20.7 x 18.5 x 5.8 inch)			
Degree of protection	IP65			
Country of Manufacture	China			
<b>Optimizer Compatibility</b>				
DC MBUS compatible optimizer	SUN2000-450W-P			
<b>Standard Compliance (more available upon request)</b>				
Certificate	EN/IEC 62109-1, EN/IEC 62109-2, IEC 62116			
Grid connection standards	AS/NZS 4777.2 2020			

<sup>1</sup> Inverter max input PV power is 20,000 Wp when long strings are designed and fully connected with SUN2000-450W-P power optimizers.

<sup>2</sup> The maximum input voltage is the upper limit of the DC voltage. Any higher input DC voltage would probably damage inverter. Please limit input voltage to maximum 600V dc according to AS4777.1 2016

<sup>3</sup> Any DC input voltage beyond the operating voltage range may result in inverter improper operating.

<sup>4</sup> SUN2000-5~10KTL-M1 raises potential between PV- and ground to above zero through integrated PID recovery function to recover module degradation from PID. Supported module types include: P-type (mono, poly).